

Transporter Wheel Attachment

Conveniently and easily transport Beltrac posts.



50-TWA01/SA



- Quickly attach to any Beltrac 3000 post with a simple twist of the knob. No tools required!
- Easily transport tall posts or posts with heavy bases quickly—just tilt and roll.
- Removes when not in use to keep posts secure.
- Constructed of sturdy, welded aluminum with 2"-diameter roller bearing wheels for smooth rolling.

 **Lavi Industries**

Products for People and the Places They Go®

© 2013 Lavi Industries All Rights Reserved.

Transporter Wheel Attachment

Conveniently and easily transport Beltrac posts.

Fits all Beltrac 3000 Posts

Product Dimensions



Operation is simple!

Place foot against crossbar of the Beltrac Wheel Attachment, firmly grasp the post and tilt back using your foot as a stopper. The post can be either pushed or pulled, depending on preference.

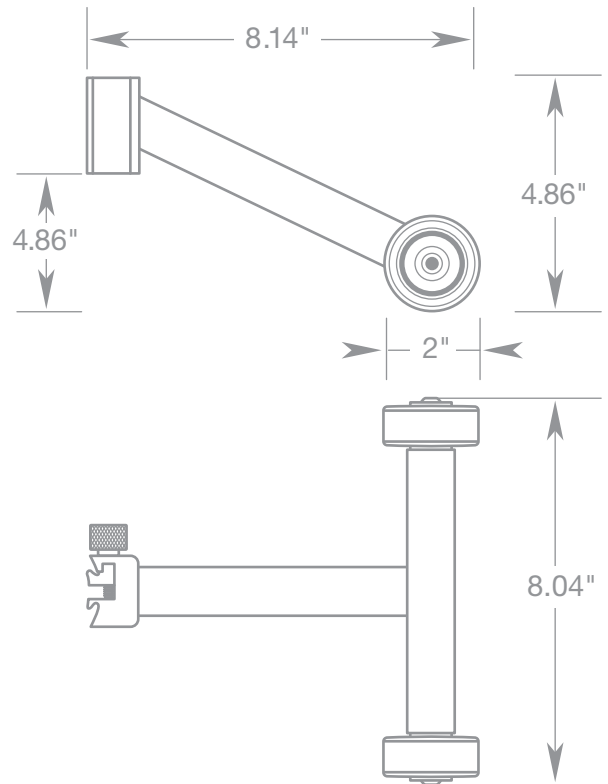

Assembly Instructions

1. Loosen the knurled knob by turning counterclockwise (**Fig. A**) and fit grip connector into the dovetail groove of the Beltrac post.
2. Slide the attachment down the dovetail groove until the wheels make contact with the floor. Then tighten the knurled knob by turning clockwise (**Fig B**) until securely fastened. *TIP: Moving the attachment slightly from side to side while tightening the grip connector ensures the removal of any slack.*
3. To remove the wheel attachment, loosen the knurled knob and remove from the dovetail groove. *Again, moving it slightly from side to side during this process will assist in releasing the grip connector.*

SPECIAL NOTE: The grip connector must be parallel to the post and base, otherwise it may not be completely secure inside the dovetail groove upon tightening. This will leave a space between the bottom of the grip connector and the top of the base (**Fig C**).

