

1.000
[25.40]

THE INFORMATION CONTAINED IN THIS DRAWING IS THE SOLE PROPERTY OF LAVI INDUSTRIES. ANY REPRODUCTION IN WHOLE OR PART WITHOUT WRITTEN PERMISSION OF LAVI INDUSTRIES IS PROHIBITED.
2012 (c) LAVI INDUSTRIES

REVISIONS		
REV.	DESCRIPTION	DATE
D01		7/21/2016

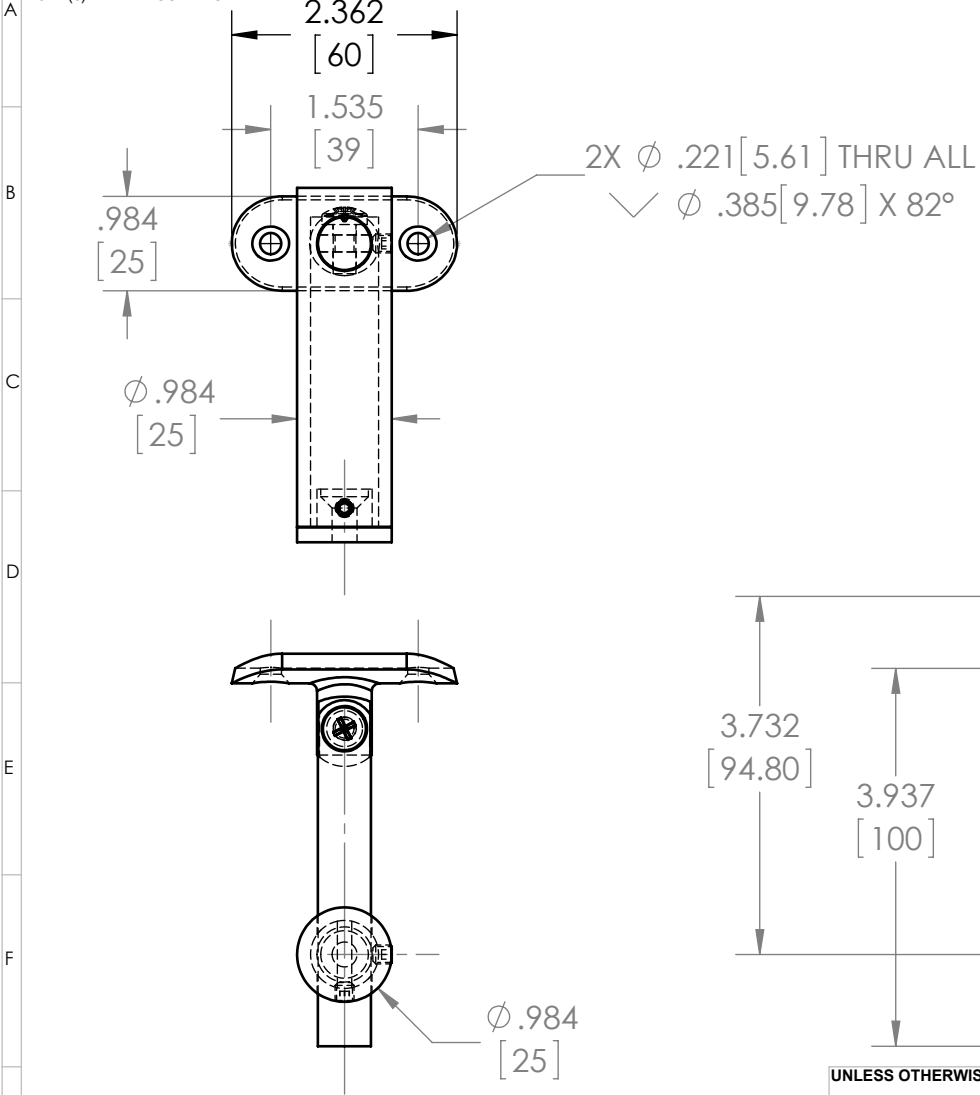

CAST LETTERING
"LAVI INDUSTRIES"

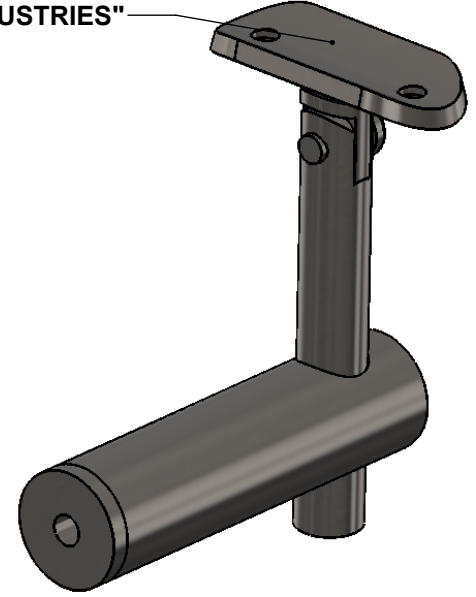

Primary dimensions are in INCHES
Secondary dims (if present) are in mm

- NOTES
1. FINISHED ITEM TO BE FREE FROM FLASH, DISTORTION, SINK MARKS OR SHARP EDGES.
 2. THIS DRG. TO BE READ INCONJUNCTION WITH 3D CAD DATA FILE.
 3. TOOL GATES AND EJECTION POINTS TO BE AGREED WITH DESIGNER PRIOR TO TOOLING.
 4. PLEASE SEE PO FOR APPROPRIATE FINISH (REQUEST FINISH LEDGER IF NOT INCLUDED)
 5. HARDWARE: 316SS, 10-24 x 1/2" PHILLIPS FLAT HEAD MACHINE SCREW (2 REQ)

UNLESS OTHERWISE SPECIFIED (INCHES)

FRACS. ±1/32" ANG. ±1°
.XX ±.03 .XXX ±.015

ISO 286-2 1988, MACHINING JS 13
FABRICATION JS 16

NAME	DATE	SIGNATURE
DRAWN waltons	7/21/2016	
CHK'D		

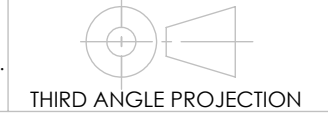

FINISH NOTES:
FOR POLISH: #8 FINISH (EQUIVALENT TO 320 GRIT)
FOR 304 SATIN: #4 FINISH (EQUIVALENT TO 180 GRIT)
FOR 316 SATIN: #6 FINISH (EQUIVALENT TO 240 GRIT)
COMMENTS:

LAVI INDUSTRIES
27810 AVENUE HOPKINS
VALENCIA, CA. 91355
Toll Free: (800) 624 6225
Eng Dept: (661) 219 3141

MATERIAL:
AISI 316 STAINLESS STEEL

WEIGHT:

REVISION: D01
DO NOT SCALE DRAWING

LAVI INDUSTRIES

TITLE/DESCRIPTION:
Handrail Bkt Sq Post, 1.5", Adj

DWG NO.
49-309PF-1H

SCALE:1:2 SHEET 1 OF 1