

Beltrac 3000

Assembly Instructions:

1. Lower tube onto base/insert. See Figure 1.
2. Bottom rim of post tube should be flat against base. See Figure 2
3. Tilt post on its side while maintaining flush fit between post and base.
4. On bottom of the base: Use supplied allen wrench (5/16) drive) to tighten the center hex bolt until tightly secured. See Figure 3.
5. Check placement of post on the base and re-tighten hex bolt.
6. Stand post upright and position post for use.

Figure 1

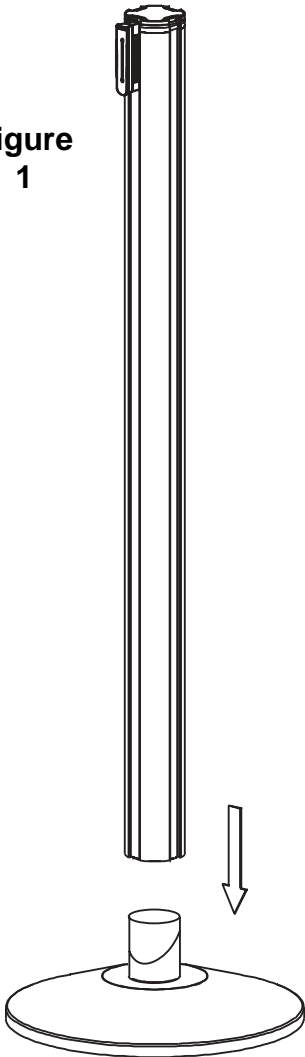

Figure 2

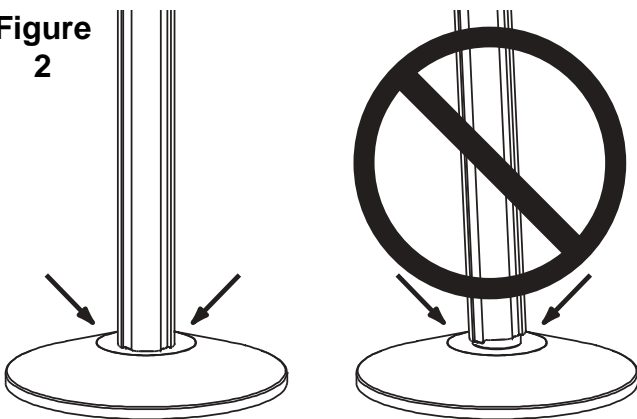
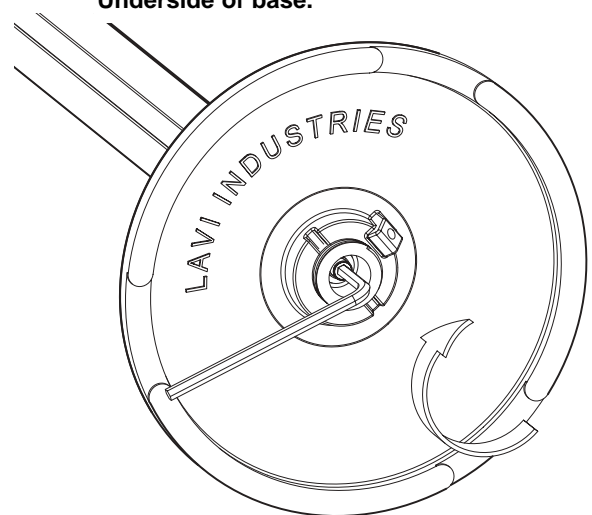

Figure 3
Underside of base.



Rev.08.07.02 3000postassembly